

CT850 TREADMILL

OWNER'S MANUAL

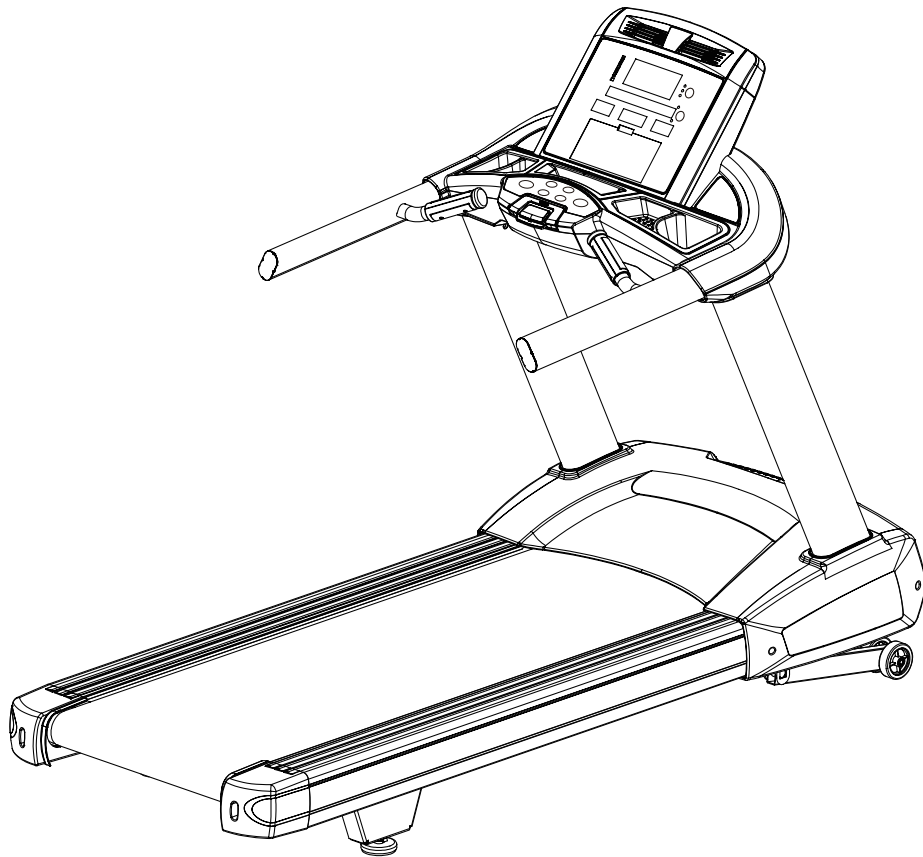

TABLE OF CONTENTS

3	IMPORTANT SAFETY INSTRUCTIONS
4	IMPORTANT ELECTRICAL INSTRUCTIONS
6	IMPORTANT OPERATION INSTRUCTIONS
6	PRODUCT REGISTRATION
8	CT850 ASSEMBLY INSTRUCTIONS
13	CONSOLE OPERATION
20	PROGRAMMABLE FEATURES
33	WEARING THE CHEST STRAP
43	GENERAL MAINTENANCE
45	MANUFACTURER'S LIMITED WARRANTY

Thank you for purchasing our product, please save these instructions. Please do not perform or attempt any customizing, adjustments, repair or maintenance that is not described in this manual.



Congratulations on your new Treadmill and welcome to the Spirit Fitness family!

Thank you for your purchase of this quality Treadmill from Spirit Fitness. Your new Treadmill was manufactured by one of the leading fitness manufacturers in the world and is backed by one of the most comprehensive warranties available. Through your dealer, Spirit Fitness will do all we can to make your ownership experience as pleasant as possible for many years to come. If not purchased direct from Spirit Fitness, the local dealership where you purchased this Treadmill is your administrator for all Spirit Fitness warranty and service needs. Their responsibility is to provide you with the technical knowledge and service personnel to make your experience more informed and any difficulties easier to remedy.

Please take a moment at this time to record the name of the dealer, their telephone number, and the date of purchase below to make any future, needed contact easy. We appreciate your support and we will always remember that you are the reason that we are in business.

Yours in Health,
Spirit Fitness

NAME OF DEALER _____

DEALER PHONE # _____

PURCHASE DATE _____

IMPORTANT SAFETY INSTRUCTIONS

DANGER - To reduce the risk of electric shock: Always unplug this appliance from the electrical outlet immediately after using and before cleaning.

WARNING

When using an electrical appliance, basic precautions should always be followed, including the following:

- To reduce the risk of burns, fire electric shock, or injury to persons.
- Read all instructions before using this appliance.
- An appliance should never be left unattended when plugged in. Unplug from outlet when not in use, and before putting on or taking off parts.
- Do not operate under blanket or pillow. Excessive heating can occur and cause fire, electric shock, or injury to persons.
- Close supervision is necessary when this appliance is used by, on, or near children, invalids, or disabled persons.
- Use this appliance only for its intended use as described in this manual. Do not use attachments not recommended by the manufacturer.
- Never operate this appliance if it has a damaged cord or plug, if it is not working properly, if it has been dropped or damaged, or dropped into water. Return the appliance to a service center for examination and repair.
- Do not carry this appliance by supply cord or use cord as a handle.
- Keep the cord away from heated surfaces.
- Never operate the appliance with the air openings blocked. Keep the air openings free of lint, hair, and the like.
- Never drop or insert any object into any opening.
- Do not use outdoors.
- Do not operate where aerosol (spray) products are being used or where oxygen is being administered.
- Connect this appliance to a properly grounded outlet only. See Grounding Instructions.
- The appliance is intended for household use.
- Maximum User Weight: 450 lbs
- This appliance is not intended for use by persons with reduced physical, sensory or mental capabilities, or lack of experience and knowledge, unless they have

been given supervision or instruction concerning use of the appliance by a person responsible for their safety.

- Keep children under the age of 13 away from this machine.
- ASTM F2115-05 Specifications 6.1.2.11 The recommended minimum clearance required around each treadmill for access to, passage around, and emergency dismount shall be stated. The minimum dimensions are to be: 0.5 m (19.7 in.) on each side of the treadmill, and 1 m (39 in.) behind the machine.

SAVE THESE INSTRUCTIONS - THINK SAFETY!

IMPORTANT ELECTRICAL INSTRUCTIONS

WARNING

NEVER use a ground fault circuit interrupt (GFCI) wall outlet with this treadmill. As with any appliance with a large motor, the GFCI will trip often. Route the power cord away from any moving part of the treadmill including the elevation mechanism and transport wheels.

NEVER remove any cover without first disconnecting AC power. If voltage varies by ten percent (10%) or more, the performance of your treadmill may be affected. Such conditions are not covered under your warranty. If you suspect the voltage is low, contact your local power company or a licensed electrician for proper testing.

NEVER expose this treadmill to rain or moisture. This product is NOT designed for use outdoors, near a pool or spa, or in any other high humidity environment. The operating temperature specification is 40 to 120 degrees Fahrenheit, and humidity is 95% non-condensing (no water drops forming on surfaces).

Circuit Breakers: Some circuit breakers used in homes are not rated for high inrush currents that can occur when a treadmill is first turned on or even during use. If your treadmill is tripping the house circuit breaker (even though it is the proper current rating) but the circuit breaker on the treadmill itself does not trip, you will need to replace the home breaker with a high inrush type. This is not a warranty defect. This is a condition we as a manufacture have no ability to control. This part

is available through most electrical supply stores. *Examples: Grainger part # 1D237, or available online at www.squared.com part #QO120HM. The electrical outlet used should have a dedicated 15 amp circuit breaker.*

GROUNDING INSTRUCTIONS

This product must be grounded. If the treadmill should malfunction or breakdown, grounding provides a path of least resistance for electric current, reducing the risk of electric shock. This product is equipped with a cord having an equipment-grounding plug. The plug must be plugged into an appropriate outlet that is properly installed and grounded in accordance with all local codes and ordinances.

DANGER - Improper connection of the equipment-grounding conductor can result in a risk of electric shock. Check with a qualified electrician or serviceman if you are in doubt as to whether the product is properly grounded. Do not modify the plug provided with the product if it will not fit the outlet; have a proper outlet installed by a qualified electrician.

This product is for use on a nominal 110-volt/15 amp dedicated circuit, and has a grounding plug that looks like the plug illustrated below. A temporary adapter that looks like the adapter illustrated below may be used to connect this plug to a 2-pole receptacle as shown below if a properly grounded outlet is not available. The temporary adapter should be used only until a properly grounded outlet, (shown pg 4) can be installed by a qualified electrician. The green colored rigid ear-lug, or the like, extending from the adapter, must be connected to a permanent ground such as a properly grounded outlet box cover. Whenever the adapter is used, it must be held in place by a metal screw.

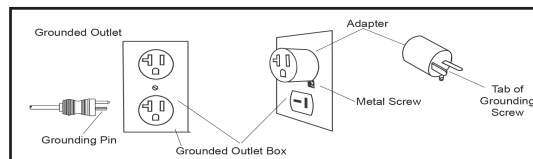

IMPORTANT OPERATION INSTRUCTIONS

- **NEVER** operate this Treadmill without reading and completely understanding the results of any operational change you request from the computer.
- Understand that changes in resistance do not occur immediately. Set your desired resistance level on the computer console and release the adjustment button. The computer will obey the command gradually.
- Use caution while participating in other activities while pedaling on your Treadmill; such as watching television, reading, etc. These distractions may cause you to lose balance which may result in serious injury.
- Do not use excessive pressure on console control buttons. They are precision set to function properly with little finger pressure.

WARNING

This product can expose you to chemicals including Toluene and Acrylamide which are known to the State of California to cause Cancer and birth defects or other reproductive harm. For more information, go to www.P65Warnings.ca.gov

RECORD YOUR SERIAL NUMBER

Please record the serial number of this fitness product in the space provided below.

Serial Number: _____

REGISTER YOUR PURCHASE

The self-addressed product registration card must be completed in full and returned to Spirit Fitness. You can also go to <http://www.spiritfitness.com/commercialwarrantyregistration.html> under the Support tab to register online.

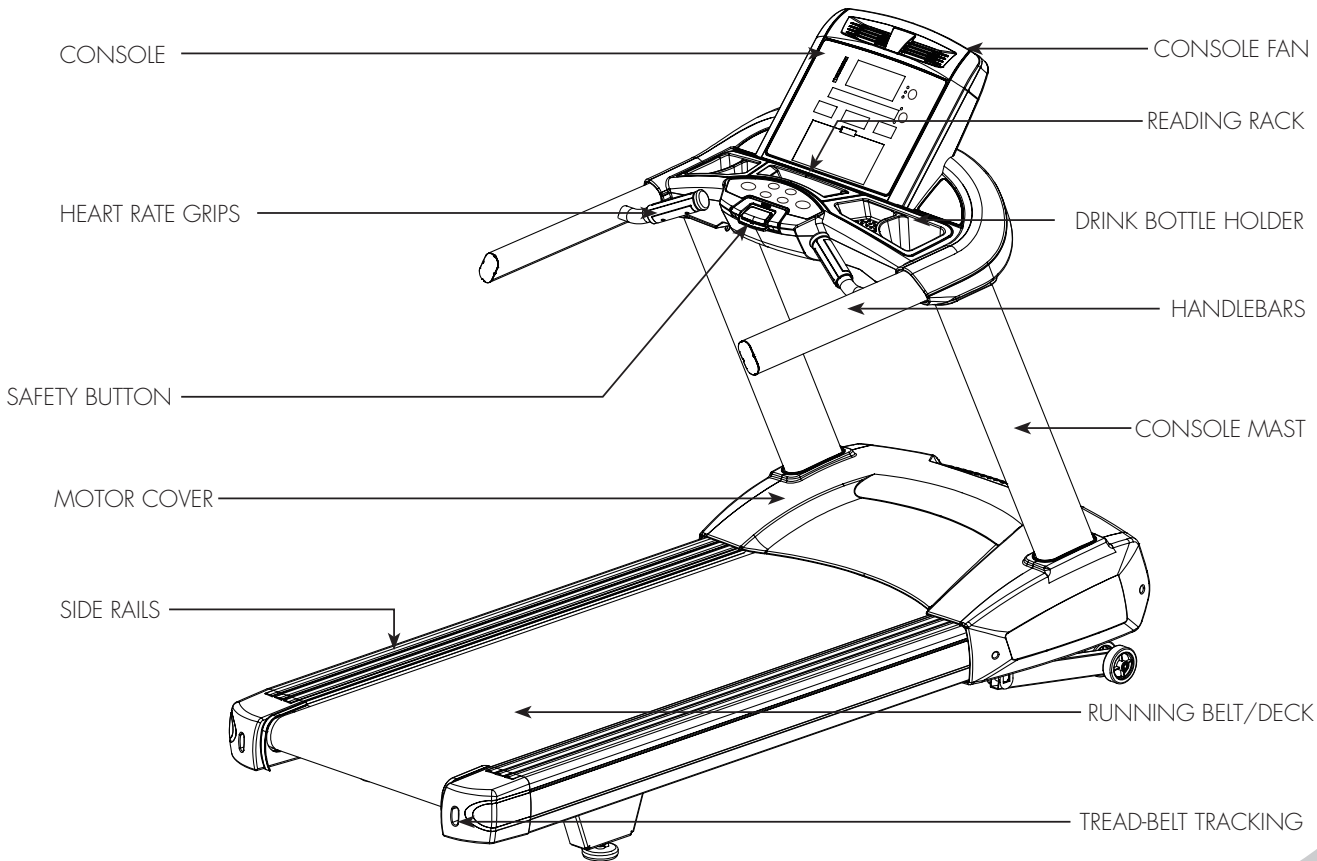

CT850 PRE-ASSEMBLY

UNPACKING

1. Cut the straps, then along the dotted line on the bottom of the box; lift the box over the unit and unpack.
2. Locate the hardware package. The hardware is separated into four steps. Remove the tools first. Remove the hardware for each step as needed to avoid confusion. The numbers in the instructions that are in parenthesis (#) are the item number from the assembly drawing for reference.

TOOLS INCLUDED:

- ❑ 3/8" Allen Wrench
- ❑ 10mm Allen Wrench
- ❑ Phillips Screwdriver

PARTS INCLUDED:

- ❑ 2 Console Masts
- ❑ 2 Side Covers
- ❑ 1 Base Frame
- ❑ 1 Console Support
- ❑ 1 Console
- ❑ 1 Safety Button
- ❑ 1 Power Cord
- ❑ 1 Tube of Lubricant (1 application)
- ❑ 1 Hardware Kit

CT850 STEP ONE

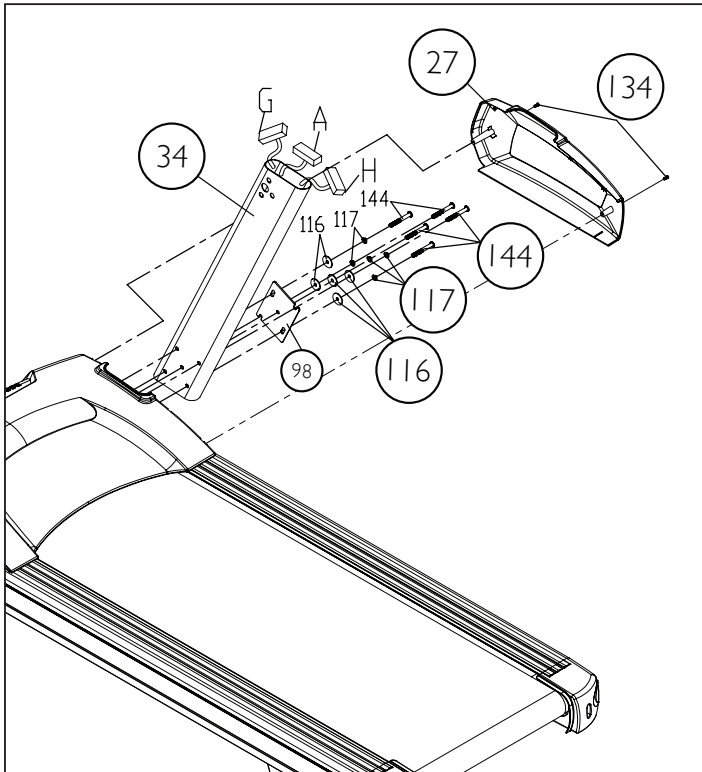

HARDWARE FOR STEP 1			
PART	TYPE	DESCRIPTION	QTY
116	FLAT WASHER	3/8"X3.5X2T	10
117	SPLIT WASHER	3/8"X16.5X2.0T	10
134	SCREW	M5X12MM	4
144	BOLT	3/8"X3"	10

1. Gather **HARDWARE FOR STEP 1**.
2. The **RIGHT UPRIGHT (34)** has a preinstalled lower **COMPUTER CABLE A (42)**. To install the uprights on the base frame, special care must be taken not to pinch the computer cable between the upright and frame base. Slide the **SPLIT WASHER (117)** and **FLAT WASHER (116)** on the **BUTTON HEAD SOCKET BOLT (144)**. Slide the **BOLT** through the top hole in the **RETAINING PLATE (98)**, and corresponding top hole in the upright tube, and screw into the base frame. Now install the other 4 **BUTTON HEAD SOCKET BOLTS (144)** together with **SPLIT WASHERS (117)**, and **FLAT WASHERS (116)**. Only hand tighten all 5 bolts. You will leave them loose until the console frame has been attached.
3. Repeat this step to install the **LEFT UPRIGHT (33)**.

CT850 STEP TWO

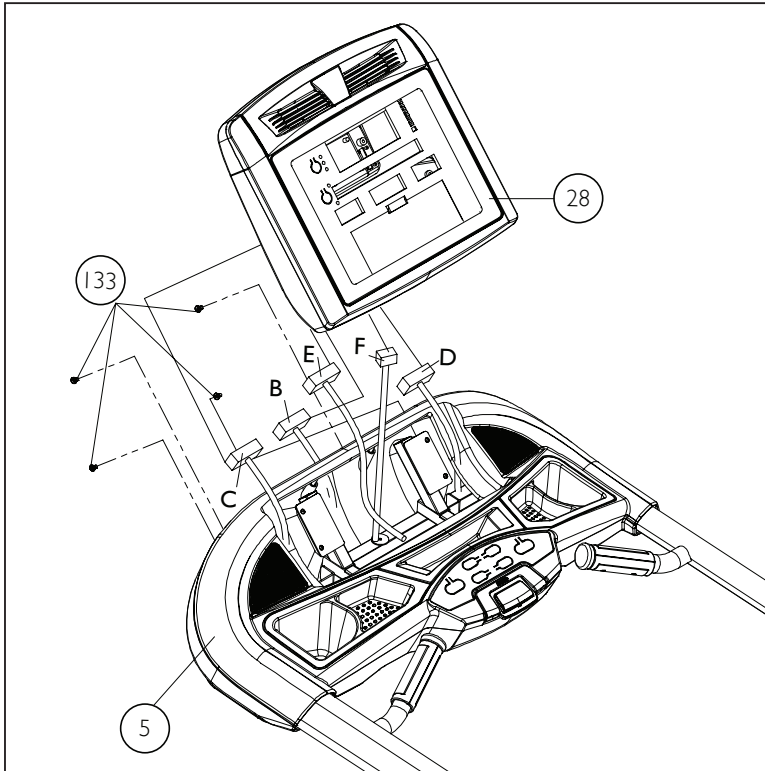

HARDWARE FOR STEP 2			
PART	TYPE	DESCRIPTION	QTY
133	SCREW	M5X12	4

1. Gather **HARDWARE FOR STEP 2**.
2. Connect the Upper **COMPUTER CABLE B** (41), **HAND PULSE ASSEMBLY C** (37), **D** (38), **TOUCH PAD/BACKLIT CABLE E** (43) and **GROUND WIRE F** (35) to the **BOARD** on the back of the **CONSOLE** (28).
3. Use 4 **PHILLIPS HEAD SCREWS** (133) to secure console assembly to the **CONSOLE SUPPORT** (5).

CT850 STEP THREE

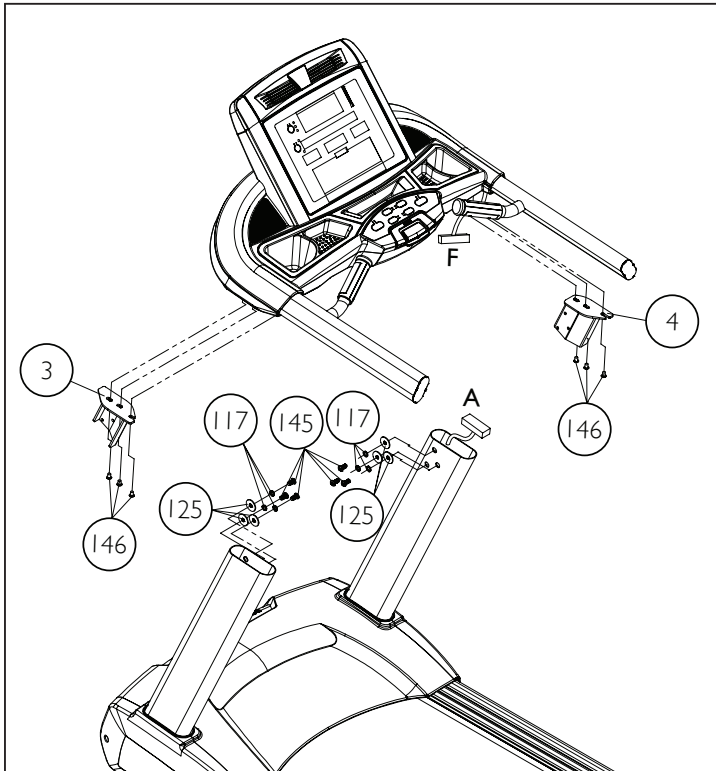

HARDWARE FOR STEP 3

PART	TYPE	DESCRIPTION	QTY
117	SPLIT WASHER	3/8"X16.5X2.0T	6
125	FLAT WASHER	3/8"X25X2T	6
145	BOLT	3/8"X3/4"	6
146	BOLT	M8X12	6

1. Gather **HARDWARE FOR STEP 3**.
2. Use 6 **SOCKET HEAD CAP BOLTS (146)** to secure the console onto the **LEFT AND RIGHT MOUNTING BRACKETS (3-L, 4-R)**. See photo below.
3. Connect the Upper **COMPUTER CABLE F (41)** to the Lower **COMPUTER CABLE A (42)**.
4. Slide the assembly into the left and right uprights.
5. Slide six **SPLIT WASHERS (117)** and 6 **FLAT WASHERS (125)** onto 6 **BUTTON HEAD SOCKET BOLTS (145)** on top of uprights. Be careful not to pinch the computer cable.

* When assembling the **CONSOLE MOUNTING INTERFACE BRACKETS (3 & 4)** please be sure to slide the brackets all the way toward the back of the console before tightening the bolts.



CT850 STEP FOUR

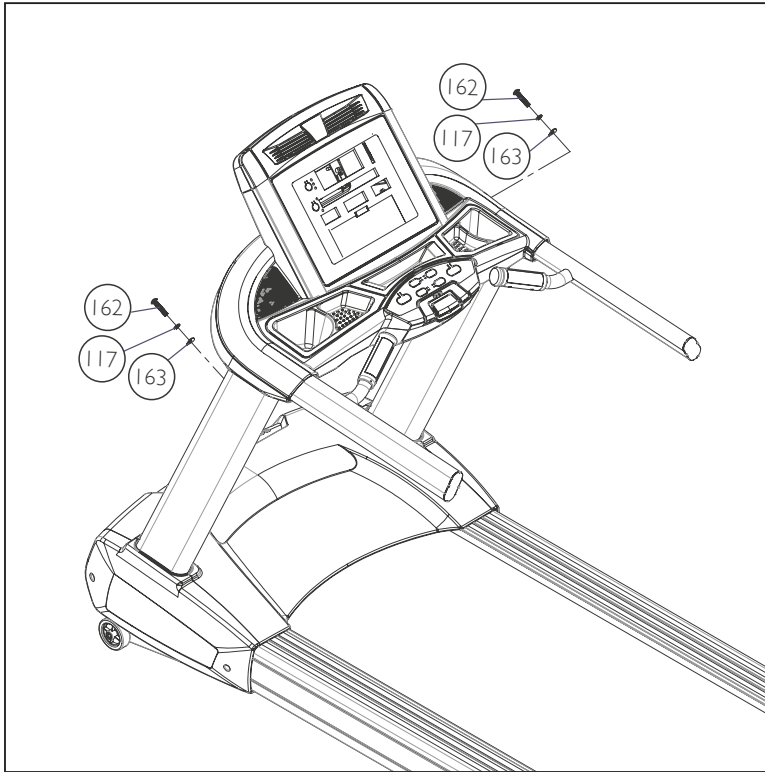

HARDWARE FOR STEP 4			
PART	TYPE	DESCRIPTION	QTY
117	SPLIT WASHER	3/8"X16.5X2.0T	2
162	BOLT	3/8"X16X1-3/4"	2
163	CURVED WASHER	10X23X1.5T	2

1. Gather **HARDWARE FOR STEP 4**.
2. Slide 2 **CURVED WASHERS (163)** and 2 **SPLIT WASHERS (117)** onto 2 **BUTTON HEAD SOCKET BOLTS (162)**. Slide the **BOLTS** through the holes on the console masts and tighten all bolts, including the ones inserted in Step 1.
3. Attach the **LEFT** and **RIGHT PLASTIC COVERS (26-L, 27-R)** with 4 **PHILLIPS HEAD SCREWS (134)**.



CT850 CONSOLE OPERATION

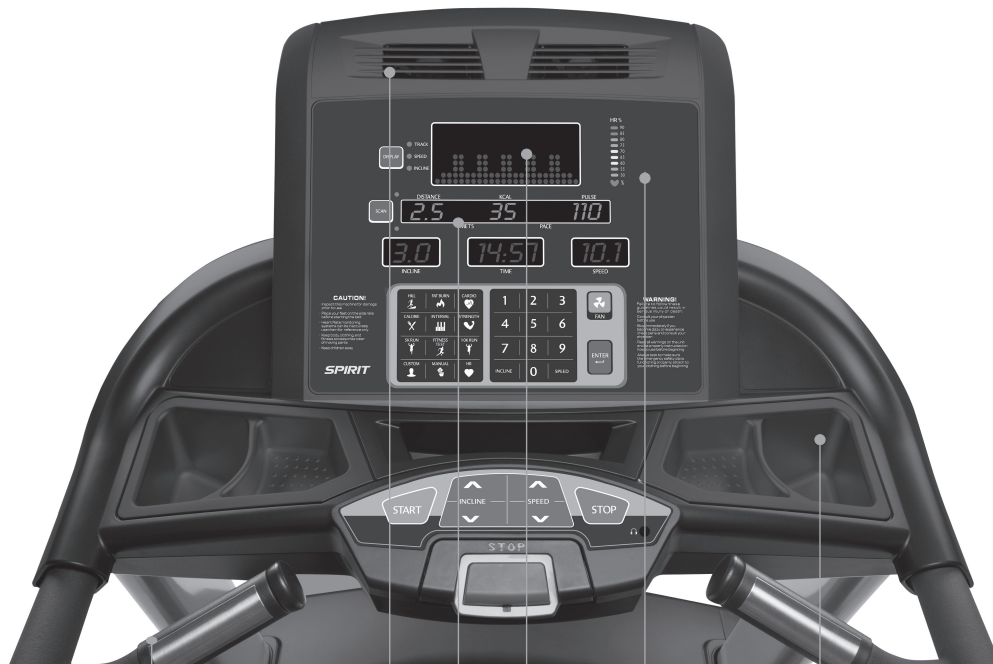

Contact Heart
Rate Grips

Fan to keep you
cool

20-Character
Message Center

Large Red-LED
Matrix Window

Heart Rate
% Profile

Convenient water bottle
holder and cargo
compartment for buttons,
phone, or MP3 player

POWER

Power the treadmill on by plugging it into an appropriate wall outlet, then turn on the power switch located at the front of the treadmill below the motor hood. Ensure that the safety button is installed, as the treadmill will not power on without it.

When the power is turned on, all the lights on the display will light for a short time. Then the **Time** and **Distance** windows will display odometer readings for a short time. The **Time** window will show how many hours the treadmill has been in use and the **Distance** window will show how many miles (or Kilometers if the treadmill is set to metric readings; see maintenance for changing settings) the treadmill has gone. A message will be displayed showing the current software version. The treadmill will then enter idle mode, which is the starting point for operation.

CSAFE FEATURE

Your console is equipped with a CSAFE feature. The Power (POWER) port can be used for powering a remote controlled audio-visual system by connecting a cable from the remote to the Power port at the back of the console. The Communication port (COMM) can be used to interact with fitness software applications.

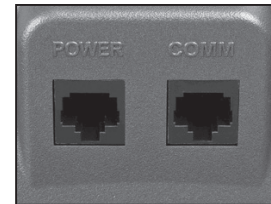

QUICK START

- Press any button to wake display up if not already on.
- Press the **Start** button to begin belt movement at 0.5 mph, then adjust to the desired speed using the **Fast/Slow** buttons, or by pressing the **Speed** button and typing the desired speed on the numeric buttonpad. Once setting desired is selected, press Enter.
- To slow tread-belt press and hold the **Slow** button to the desired speed. You may also use the numeric buttonpad to input your desired speed. Once setting desired is selected, press **Enter**.
- To stop the tread-belt press and release **Stop** button.

PAUSE/STOP/PRESET

- When the treadmill is running the pause feature may be utilized by pressing the red **Stop** button once. This will slowly decelerate the tread-belt to a stop. The incline will go to zero percent. The **Time**, **Distance** and **Calorie** readings will hold while the unit is in the pause mode. After 5 minutes the display will reset and return to the start up screen.
- To resume your exercise when in **Pause** mode, press the **Start** button. The speed and incline will return to their previous settings.
- Pressing the **Stop** button twice will end the program and a workout summary will be displayed. If the **Stop** button is pressed a third time, the console will return to the idle mode (start up) screen.
- If the **Stop** button is held down for more than three seconds the console will reset.
- When you are setting data, such as age and time, for a program pressing the **Stop** button will allow you to go back one step for each button press.

INCLINE

- Incline may be adjusted anytime after the belt starts moving.
- Press and hold the adjust Up / Down buttons to achieve desired level of effort, or by pressing the Incline button and typing the desired incline on the numeric buttonpad. Once setting desired is selected, press Enter.
- The display will indicate incline numbers as percent of grade (the same as grade of a road) as adjustments are made.

DOT MATRIX CENTER DISPLAY

Ten rows of dots indicate each level of a workout in manual mode. The dots are only to show an approximate level (speed/incline) of effort. They do not necessarily indicate a specific value - only an approximate percent to compare levels of intensity. In Manual Operation the Speed / Incline dot matrix window will build a profile “picture” as values are changed during a workout. There are twenty-four columns, indicating time. The 24 columns are divided into 1/24th of the total time of the program. When the time is counting up from zero (as in quick start) each column represents 1 minute.

Next to the Dot Matrix window are three LED lights labeled: **Track**, **Speed** and **Incline**, along with a display button. When the **Track** LED is lit the dot matrix displays the **Track** profile, when the **Speed** LED is lit the Dot matrix displays the **Speed** profile and when the **Incline** LED is lit the Dot Matrix displays the **Incline** profile. You may change the Dot Matrix profile view by pressing the **Display** button. After scrolling through the three profiles the Dot matrix will automatically scroll through the three displays showing each one for four seconds. The LED associated with each profile will blink while that view is displayed. One more press of the **Display** button will return you to the **Track** profile.

1/4 MILE TRACK

The 1/4-mile track (0.4 km) will be displayed around the dot matrix window. The flashing dot indicates your progress. In the center of the track there is a lap counter for reference.

HEART RATE FEATURE

The Pulse (Heart Rate) window will display your current heart rate in beats per minute during the workout. You must use both left and right stainless steel sensors to pick up your pulse. Pulse values are displayed anytime the computer is receiving a Grip Pulse signal. You may use the Grip Pulse feature while in Heart Rate Control. The CT850 will also pick up wireless heart rate transmitters that are Polar compatible, including coded transmissions.

HEART RATE BAR GRAPH

Displays a graphical representation of your heart rate as a percentage of your estimated maximum heart rate. When you enter your age during programming, the console will calculate your maximum heart rate then light up the graph to show the percent of estimated maximum heart rate you are currently achieving.

MESSAGE WINDOW DISPLAY

Displays messages that help guide you through the programming process. During a program the message window displays your workout data.

TO TURN TREADMILL OFF

The display will automatically turn off (go to sleep) after 30 minutes of inactivity. This function is called sleep mode. In sleep mode, the treadmill will power down most everything except for a minimum of circuitry for detecting button presses and the safety button so it will start up again if these are activated. There is only a tiny amount of current used in sleep mode (about the same as your TV when it is turned off) and it is perfectly fine to leave the main power switch on in sleep mode. Of course you may also remove the safety button or turn off the main power switch to power down the treadmill.

PROGRAMMABLE FEATURES

The Spirit Fitness CT850 offers twelve preset programs: Hill, Fat Burn, Cardio, Calorie, Interval, Strength, 5K Run, 10K Run, HR 1, HR 2, a Custom User defined program, a Gerkin Protocol based Fitness Test and one Manual program.

1. Select a program then press the **Enter** button to begin customizing the program with your personal data, or just press the **Start** button to begin the program with the default settings.
2. After selecting a program and pressing enter to set your personal data, the **Time** window will blink with the default value of 20 minutes. You may use any of the **Up/Down** buttons to adjust the time. After adjusting the time, press **Enter**. (Note: Except for the Calorie Program, you may press **Start** at any time during the programming to begin with only settings you have modified at that point).
3. The **Incline** window will now be blinking a value indicating your **Age**. Entering the correct age will affect the Heart Rate Bar Graph accuracy and also needed for the HR programs. Use the **Up/Down** buttons to adjust, and then press enter.
4. The **Distance** window will now be blinking a value indicating your **Bodyweight**. Entering your correct bodyweight affects the Calorie readout accuracy. Use the **Up/Down** buttons to adjust, and then press **Enter**.
5. The **Speed** window will now be blinking, showing the preset top speed of the selected program. Use the **Up/Down** buttons to adjust, and then press **Enter**. Each program has various speed changes throughout; this allows you to limit the highest speed the program will attain during your workout.
6. Now press the **Start** button to begin your workout, or the **Stop** button to return to the previous screen.
7. There will be a three minute warm-up to begin. You can press the **Start** button to bypass this and go straight to the workout. During the warm-up the clock will count down from three minutes. (5K Run, 10K Run, HR 1, HR 2, Custom, and Manual do not have warm-up)

PRESET PROGRAMS SPEED/INCLINE SETTINGS

The preset program Speed and Incline levels are shown in the chart below. The Speed numbers shown in the chart indicate a percentage of the top speed of the program. For instance, the first Speed setting for P1 (Program 1, HILL) shows the number 20. This means that this segment of the program will have a speed that is 20% of the top speed for the program (The user sets the top speed in the procedure above). If the user sets the top speed to 10 mph, then the first segment will be 2 mph. You will notice that segment 12 shows 100 which means, the speed will be set to 100% of 10 mph or simply 10 mph.

P1= Hill; P2= Fatburn; P3= Cardio; P4= Interval; P5= Calorie; P6= Strength

Prog	SEG	Warm up			1	2	3	4	5	6	7	8	9	10	11	12	13	14	15	16	17	18	19	20	21	22	23	24	Cool down				
P1	Speed	20	30	40	50	60	60	70	70	70	80	80	70	80	80	100	100	70	80	80	70	70	80	80	70	60	60	50	40	30	20		
	Incline	0	0	0	0	1	2	3	3	4	3	3	4	4	5	3	3	4	3	3	4	4	5	4	3	1	1	0	0	0	0		
P2	Speed	20	30	40	50	60	60	70	80	100	100	100	100	100	100	100	100	100	100	100	100	100	100	100	80	70	60	50	40	30	20		
	Incline	0	0	0	0	1	2	3	3	3	4	5	3	3	4	4	3	3	2	2	3	4	5	6	4	2	1	0	0	0	0		
P3	Speed	20	30	40	50	60	60	70	70	70	80	70	70	80	80	60	70	80	80	70	70	70	100	70	80	60	60	50	40	30	20		
	Incline	0	0	0	0	1	1	1	2	2	3	2	2	3	3	1	2	3	3	2	2	4	4	2	3	1	1	0	0	0	0		
P4	Speed	20	30	40	50	60	60	70	80	100	60	60	70	80	100	60	70	100	60	70	100	60	70	80	70	60	60	50	40	30	20		
	Incline	0	0	0	0	1	2	3	5	6	2	3	5	6	7	2	3	7	2	3	8	2	3	5	4	3	1	0	0	0	0		
P5	Speed	20	30	40	50	50	60	80	90	100	70	100	70	100	70	100	70	100	70	100	70	100	90	80	70	60	50	50	40	30	20		
	Incline	0	0	0	0	0	0	0	0	0	0	0	0	0	0	0	0	0	0	0	0	0	0	0	0	0	0	0	0	0	0		
P6	Speed	20	30	40	50	60	60	70	70	80	80	90	90	90	100	100	100	100	100	100	100	100	100	100	90	80	60	50	40	30	20		
	Incline	0	0	0	1	1	1	4	4	4	4	4	4	4	5	5	5	5	5	5	5	5	5	5	3	3	3	3	3	1	1	0	0

CALORIE PROGRAM

1. Press the **Calorie** button to initiate the program. The Message Window shows "PRESS ENTER TO MODIFY."
2. Press **Enter** button, the Message Window shows "ADJUST AGE THEN PRESS ENTER" and the Incline Window is blinking. After the age is set, press **Enter** to continue.
3. Message Window is showing "ADJUST BODY WEIGHT THEN PRESS ENTER" and INCLINE window is blinking. After the weight is set, press **Enter** button to continue.
4. Message Window is showing "ADJUST TARGET CALORIE BURN THEN PRESS ENTER" and the Incline Window is blinking. After setting CALORIE target, press **Enter** button to continue.
5. Message Window is now showing "ADJUST MAX. SPEED THEN PRESS ENTER" and the Speed Window is blinking. After maximum speed is set, press **Enter** button to continue.
6. Message Window is now showing "ADJUST MAX. INCLINE THEN PRESS ENTER" and the Incline Window is blinking. After maximum incline is set, press the **Enter** button. The Message Window shows "PROGRAM TIME". The console then automatically calculates the time needed to burn the desired Calories and shows it in Time Window.
7. Now Message Window is showing "PRESS START TO BEGIN WORKOUT OR ENTER TO MODIFY". Press **Start** button to begin the workout or the **Stop** button to return to the previous screen.

CUSTOM PROGRAM

1. When you select the Custom program, the Message Window shows “PRESS ENTER TO MODIFY OR START TO BEGIN WORKOUT”. You can either press the **Enter** button or the **Start** button to begin the workout. When you press **Enter**, the **Dot Matrix Window** will show U1 and is flashing. In the mean time, the Message Window will show “PRESS 1 OR 2 TO SELECT THEN PRESS ENTER”. You can choose U1 or U2 for setting by pressing **1** or **2** button then the **Enter** button. Note that the Dot Matrix Display portion will light a single row of dots at the bottom (Unless there is a previously saved program).
2. After pressing the **Enter** button, the Message Window displays “ADJUST TIME THEN PRESS ENTER” with Time Window blinking. Use the **Up/Down/Fast/Slow** or numeric buttonpads to adjust and set the program for the desired time. Press the **Enter** button. This is a must to continue even if the time is not adjusted.
3. Now the Message Window is showing “ADJUST AGE THEN PRESS ENTER”. The Incline Window will now be blinking a value indicating your age. Entering the correct age will affect the Heart Rate Bar Graph accuracy. Use **Up/Down/Fast/Slow** buttons or numeric buttons to adjust and then press **Enter** button.
4. Now the Message Window is showing “ADJUST BODY WEIGHT THEN PRESS ENTER”. The Incline window will now be blinking a value indicating your bodyweight. Entering your correct bodyweight affects the calorie readout accuracy. Use **Up/Down/Fast/Slow** buttons or numeric buttons to adjust, and then press **Enter** button.
5. Now the Message Window is showing “ADJUST SPEED THEN PRESS ENTER”. The first speed column (segment) will be blinking along with the Speed Window. To set the speed value you want, use the **Up/Down/Fast/Slow** buttons to adjust the speed to your desired effort level for the first segment, then press **Enter**. The second column will now be blinking. Note that the previous segment value has been carried over to the new segment. Repeat the above process until all segments have been programmed.
6. Now the Message Window is showing “ADJUST INCLINE THEN PRESS ENTER”. The first column will be blinking again and so will the Incline Window. The console is now ready for the incline settings. To set the incline value you want, use **Up/Down/Fast/Slow** buttons to adjust the incline to your desired effort level for the first segment, then press **Enter**. Repeat the same process used to set the speed values for programming the segments for incline.

7. When the setting is completed, the Message Window will show "PRESS START TO BEGIN WORKOUT OR ENTER TO MODIFY" .Press the **Start** button to begin the workout and also save the program to memory or press the **Stop** button to return to the previous screen.

5K/10K RUN

This program automatically sets a 5K or 10K (5 or 10 kilometer) distance as your goal. The track display will show one loop that is the equivalent of 5 or 10 kilometers and the Distance window will also show 5K or 10K to start. When the program begins the Distance will count down; once it reaches zero the program ends.

**Please note that the Speed readout is in MPH if the console is not set to Metric.*

FITNESS TEST

When the Fit-Test button is pressed the DM displays the 5 different tests available: Army (PFT), Navy (PRT), Air Force (PRT), Marines (PFT), and Gerkin. To select your desired fitness test use the arrow button and press enter.

FITNESS TEST OPERATION

1. The **Message Window** will ask you to enter your **Weight**. You may adjust the weight setting, shown in the **Incline** window, using the **Up** and **Down** buttons then press the **Enter** button to accept the new number and proceed on to the next screen.
2. You are now asked to enter your **Age**. You may adjust the age setting, shown in the **Incline** window, using the **Up** and **Down** buttons then press **Enter** to continue.
3. You are now asked to enter your **Gender**. You may adjust the gender setting, shown in the **Incline** window, using the **Up** and **Down** buttons then press **Enter** to continue.
4. Now press **Start** to begin the test.

ARMY

A timed 2 mile run. You control the speed manually.
Maximum time allowed to pass the test:

Age	Male	Female
17-21	16:36	19:42
22-26	17:30	20:36
27-31	17:54	21:42
32-36	18:48	23:06
37-41	19:30	24:06

For more detailed information visit: <http://bit.ly/SF-Army>

NAVY

A timed 1.5 mile run. You control the speed manually.
Maximum time allowed to pass the test:

Age	Male	Female
17-21	16:36	19:42
22-26	17:30	20:36
27-31	17:54	21:42
32-36	18:48	23:06
37-41	19:30	24:06

Age	Male	Female
45-49	16:09	17:02
50-54	16:46	17:27
55-59	17:10	18:35
60-64	18:53	19:44
65+	20:36	20:53

For more detailed information visit: <http://bit.ly/SF-Navy>

AIR FORCE

A timed 1.5 mile run. You control the speed manually.
Maximum time allowed to pass the test:

Age	Male	Female
<20	12:36	16:22
20-30	14:00	16:57
40-49	14:52	18:14
50-59	16:22	19:42
60+	18:14	22:28

For more detailed information visit: <http://bit.ly/SF-AirForce>

MARINES

A timed 3 mile run. You control the speed manually.
Maximum time allowed to pass the test:

Age	Male	Female
17-26	28:00	31:00
27-39	29:00	32:00
40-45	30:00	33:00
46+	33:00	36:00

For more detailed information visit: <http://bit.ly/SF-Marines>

GERKIN

The Gerkin protocol, also known as the fireman's protocol, and is a submax Vo2 (volume of oxygen) test. The test will increase speed and elevation alternately until you reach 85% of your Max heart rate. The time it takes for you to reach 85% determines the test score (Vo2 max) as shown in the chart below.

Stage	Time	Speed	Grade	VO2 Max
1	0 to 1:00	4.5mph	0%	31.15
2.1	1:00	4.5mph	2%	32.55
2.2	1:30	4.5mph	2%	33.6
2.3	1:45	4.5mph	2%	34.65
2.4	2:00	5.0mph	2%	35.35
3.1	2:15	5.0mph	2%	37.45
3.2	2:30	5.0mph	2%	39.55
3.3	2:45	5.0mph	2%	41.3
3.4	3:00	5.0mph	4%	43.4
4.1	3:15	5.0mph	4%	44.1
4.2	3:30	5.0mph	4%	45.15
4.3	3:45	5.0mph	4%	46.2
4.4	4:00	5.5mph	4%	46.5
5.1	4:15	5.5mph	4%	48.6
5.2	4:30	5.5mph	4%	50
5.3	4:45	5.5mph	4%	51.4
5.4	5:00	5.5mph	6%	52.8
6.1	5:15	5.5mph	6%	53.9
6.2	5:30	5.5mph	6%	54.9
6.3	5:45	5.5mph	6%	56

6.4	6:00	6.0mph	6%	57
7.1	6:15	6.0mph	6%	57.7
7.2	6:30	6.0mph	6%	58.8
7.3	6:45	6.0mph	6%	60.2
7.4	7:00	6.0mph	8%	61.2
8.1	7:15	6.0mph	8%	62.3
8.2	7:30	6.0mph	8%	63.3
8.3	7:45	6.0mph	8%	64
8.4	8:00	6.5mph	8%	65
9.1	8:15	6.5mph	8%	66.5
9.2	8:30	6.5mph	8%	68.2
9.3	8:45	6.5mph	8%	69
9.4	9:00	6.5mph	10%	70.7
10.1	9:15	6.5mph	10%	72.1
10.2	9:30	6.5mph	10%	73.1
10.3	9:45	6.5mph	10%	73.8
10.4	10:00	7.0mph	10%	74.9
11.1	10:15	7.0mph	10%	76.3
11.2	10:30	7.0mph	10%	77.7
11.3	10:45	7.0mph	10%	79.1
11.4	11:00	7.0mph	10%	80

FITNESS TEST PROGRAMMING

1. Press the **Fit-Test** button and press **Enter**.
2. The **Message Window** will ask you to enter your **Age**. You may adjust the age setting, shown in the **Incline** window, using the **Up** and **Down** buttons then press the **Enter** button to accept the new number and proceed on to the next screen.
3. You are now asked to enter your **Weight**. You may adjust the weight setting, shown in the **Distance** window, using the **Up** and **Down** buttons then press **Enter** to continue.
4. Now press **Start** to begin the test.

Before the Test:

1. Make sure you are in good health; check with your physician before performing any exercise if you are over the age of 35 or persons with pre-existing health conditions.
2. Make sure you have warmed up and stretched before taking the test.
3. Do not take in caffeine before the test.
4. Hold the hand grips gently, do not tense up.

During The Test:

1. The console must be receiving a steady heart rate for the test to begin. You may use the hand pulse sensors or wear a heart rate chest strap transmitter.
2. The test will start with a 3 minute warm-up at 3 MPH before the actual test begins.
3. The data shown during the test is:
 - a. Time indicates total elapsed time
 - b. Incline in percent grade
 - c. Distance in Miles or Kilometers depending on preset parameter.
 - d. Speed in MPH or KPH depending on preset parameter.
 - e. Target Heart Rate and Actual Heart Rate are shown in the **Message Window**.

After The Test:

1. Cool down for about one to three minutes.
2. Take note of your score because the console will automatically return to the start-up mode after a few minutes.

What Your Score Means:

VO2MAX CHART FOR MALES AND VERY FIT FEMALES

	18-25 years old	26-35 years old	36-45 years old	46-55 years old	56-65 years old	65+ years old
excellent	>60	>56	>51	>45	>41	>37
good	52-60	49-56	43-51	39-45	36-41	33-37
above average	47-51	43-48	39-42	35-38	32-35	29-32
average	42-46	40-42	35-38	32-35	30-31	26-28
below average	37-41	35-39	31-34	29-31	26-29	22-25
poor	30-36	30-34	26-30	25-28	22-25	20-21
very poor	<30	<30	<26	<25	<22	<20

VO2MAX CHART FOR FEMALES AND DE-CONDITIONED MALES

	18-25 years old	26-35 years old	36-45 years old	46-55 years old	56-65 years old	65+ years old
excellent	56	52	45	40	37	32
good	47-56	45-52	38-45	34-40	32-37	28-32
above average	42-46	39-44	34-37	31-33	28-31	25-27
average	38-41	35-38	31-33	28-30	25-27	22-24
below average	33-37	31-34	27-30	25-27	22-24	19-22
poor	28-32	26-30	22-26	20-24	18-21	17-18
very poor	<28	<26	<22	<20	<18	<17

HEART RATE PROGRAMS

The old motto, “no pain, no gain”, is a myth that has been overpowered by the benefits of exercising comfortably. A great deal of this success has been promoted by the use of heart rate monitors. With the proper use of a heart rate monitor, many people find that their usual choice of exercise intensity was either too high or too low and exercise is much more enjoyable by maintaining their heart rate in the desired benefit range.

To determine the benefit range in which you wish to train, you must first determine your Maximum Heart Rate. This can be accomplished by using the following formula: 220 minus your age. This will give you the Maximum Heart Rate (MHR) for someone of your age. To determine the effective heart rate range for specific goals you simply calculate a percentage of your MHR. Your Heart rate training zone is 50% to 90% of your maximum heart rate. 60% of your MHR is the recommended for burning fat while 80% is recommended for strengthening the cardio vascular system. This 60% to 80% is the zone to stay in for maximum benefit.

For someone who is 40 years old their target heart rate zone is calculated:

$220 - 40 = 180$ (maximum heart rate)

$180 \times .6 = 108$ beats per minute (60% of maximum)

$180 \times .8 = 144$ beats per minute (80% of maximum)

So for a 40 year old the training zone would be 108 to 144 beats per minute.

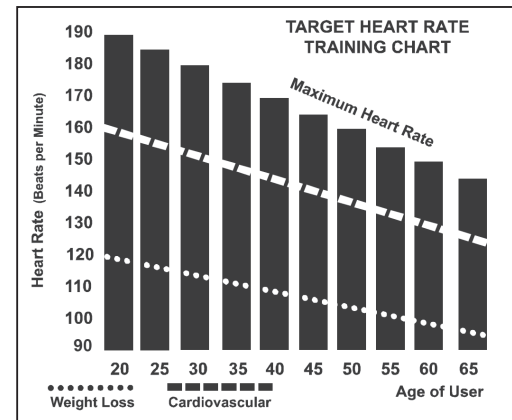

If you enter your age during programming the console will perform this calculation automatically. Entering your age is used for the Heart Rate programs. After calculating your MHR you can decide upon which goal you would like to pursue.

The two most popular reasons for, or goals, of exercise are cardiovascular fitness (training for the heart and lungs) and weight control. The black columns on the chart above represent the MHR for a person whose age is listed at the bottom of each column. The training heart rate, for either cardiovascular fitness or weight loss, is represented by two different lines that cut diagonally through the chart. A definition of the lines' goal is in the bottom left-hand corner of the chart. If your goal is cardiovascular fitness or if it is weight loss, it can be achieved by training at 80% or 60%, respectively, of your MHR on a schedule approved by your physician. Consult your physician before participating in any exercise program.

With all Spirit Fitness Heart Rate programs you may use the heart rate monitor feature without using the Heart Rate program. This function can be used during manual mode or during any of the nine different programs. The Heart Rate program automatically controls resistance at the pedals.

RATE OF PERCEIVED EXERTION

Heart rate is important but listening to your body also has a lot of advantages. There are more variables involved in how hard you should workout than just heart rate. Your stress level, physical health, emotional health, temperature, humidity, the time of day, the last time you ate and what you ate, all contribute to the intensity at which you should workout. If you listen to your body, it will tell you all of these things.

The rate of perceived exertion (RPE), also know as the Borg scale, was developed by Swedish physiologist G.A.V. Borg. This scale rates exercise intensity from 6 to 20 depending upon how you feel or the perception of your effort. The scale is as follows:

Rating Perception of Effort

6 Minimal	10 Very light +	14 Somewhat hard +	18 Very hard +
7 Very,very light	11 Fairly light	15 Hard	19 Very,very hard
8 Very,very light +	12 Comfortable	16 Hard +	20 Maximal
9 Very light	13 Somewhat hard	17 Very hard	

You can get an approximate heart rate level for each rating by simply adding a zero to each rating. For example a rating of 12 will result in an approximate heart rate of 120 beats per minute. Your RPE will vary depending up the factors discussed earlier. That is the major benefit of this type of training. If your body is strong and rested, you will feel strong and your pace will feel easier. When your body is in this condition, you are able to train harder and the RPE will support this. If you are feeling tired and sluggish, it is because your body needs a break. In this condition, your pace will feel harder. Again, this will show up in your RPE and you will train at the proper level for that day.

WEARING THE CHEST STRAP

1. Attach the transmitter to the elastic strap using the interlocking button.
2. Adjust the strap as tightly as possible as long as the strap is not too tight to remain comfortable.
3. Position the transmitter with the logo centered in the middle of your torso facing away from your chest (some people must position the transmitter slightly left of center). Attach the final end of the elastic strap by inserting the round end and, using the locking parts, secure the transmitter and strap around your chest.
4. Position the transmitter directly below the pectoral muscles.
5. Sweat is the best conductor to measure very minute heart beat electrical signals. However, plain water can also be used to pre-wet the electrodes (2 ribbed oval areas on the reverse side of the belt and both sides of the transmitter). It's also recommended that you wear the transmitter strap a few minutes before your work out. Some users, because of body chemistry, have a more difficult time in achieving a strong, steady signal at the beginning. After "warming up", this problem lessens.
6. Your workout must be within range - distance between transmitter/receiver – to achieve a strong steady signal. The length of range may vary somewhat but generally stay close enough to the console to maintain good, strong, reliable readings. Wearing the transmitter directly on bare skin assures you of proper operation. If you wish, you may wear the transmitter over a shirt. To do so, wet the areas of the shirt that the electrodes will rest upon.

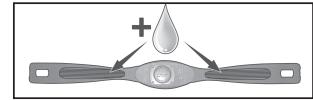

NOTE: The transmitter is automatically activated when it detects activity from the user's heart. Additionally, it automatically deactivates when it does not receive any activity. Although the transmitter is water resistant, moisture can have the effect of creating false signals, so you should take precautions to completely dry the transmitter after use to prolong battery life (estimated transmitter battery life is 2500 hours). The replacement battery is Panasonic CR2032.

ERRATIC OPERATION

Caution! Do not use this Treadmill for Heart Rate programs unless a steady, solid Actual Heart Rate value is being displayed. High, wild, random numbers being displayed indicate a problem.

Areas to look for interference which may cause erratic heart rate:

1. Microwave ovens, TV's, small appliances, etc.
2. Fluorescent lights.
3. Some household security systems.
4. Perimeter fence for a pet.
5. Some people have problems with the transmitter picking up a signal from their skin. If you have problems try wearing the transmitter upside down. Normally the transmitter will be oriented so the Spirit Fitness logo is right side up.
6. The antenna that picks up your heart rate is very sensitive. If there is an outside noise source, turning the whole machine 90 degrees may de-tune the interference.
7. Another Individual wearing a transmitter within 3' of your machine's console.

If you continue to experience problems contact your dealer.

HEART RATE CONTROL

How the Heart Rate Control Programs Work: Heart Rate Control (HRC) uses your treadmill's incline system to control your heart rate. Increases and decreases in elevation affect heart rate much more efficiently than changes in speed alone. The HRC program automatically changes elevation gradually to achieve the programmed target heart rate.

Selecting a Heart Rate Control Program: You have the option, during the setup mode, to choose either the Weight Control (HR-1) program or the Cardiovascular (HR-2) program. The Weight Control program will attempt to maintain your heart rate at 60% of your Maximum Heart Rate. The Cardiovascular program will attempt to maintain your heart rate at 85% of your Maximum Heart Rate. Your Maximum Heart Rate is based upon a formula that subtracts your age from a constant of 220. Your HR setting is automatically calculated during the setup mode when you enter your age.

HEART RATE CONTROL PROGRAMMING

1. Press **HR** button to enter heart rate program.
2. Now the window will show "PRESS ENTER TO MODIFY OR START TO BEGIN WORKOUT". You can either press the **Enter** button for settings or press the **Start** button to execute the program.
3. When the **Enter** button is pressed, the Message Window shows "PRESS 1 OR 2 TO SELECT THEN PRESS ENTER". At the same time, the dot matrix window is showing "1" and you can press numeric buttonpad 1 or 2 and then the **Enter** button.
4. Now Message Window is showing "ADJUST TIME THEN PRESS ENTER" with Time Window blinking. Use **Up/Down/Fast/Slow** buttons or numeric buttons to adjust. After setting time, press the **Enter** button again.
5. Now Message Window is showing "ADJUST AGE THEN PRESS ENTER" with Incline Window blinking. Use **Up/Down/Fast/Slow** buttons or numeric buttons to adjust. Adjusting age will change THR value (as the THR formula described above). After age is set, press the **Enter** button again.

6. Now Message Window is showing "ADJUST BODY WEIGHT THEN PRESS ENTER" with Incline Window blinking. Use **Up/Down/Fast/Slow** buttons or numeric buttons to adjust. After the weight is set, press **Enter** button again.
7. Now Message Window is showing "ADJUST HEART RATE THEN PRESS ENTER" with Speed Window blinking. Use **Up/Down/Fast/Slow** buttons or numeric buttons to adjust. After the target heart rate value is set, Press the **Enter** button again.
8. The Message Window is then showing "PRESS START TO BEGIN WORKOUT OR ENTER TO MODIFY". Press **Start** button to begin the workout or **Stop** button to return to the previous screen.

NOTE: When the Message Window is showing "CHECK PULSE", there is no pulse signal received and the program can not be performed. Please check and make sure that heart rate strap functions normally.

SAFETY TETHER CORD

A safety tether cord is provided with this unit. It is a simple magnetic design that should be used at all times. It is for your safety should you fall or move too far back on the tread-belt. Pulling this safety tether cord will stop tread-belt movement. To Use:

1. Place the magnet into position on the round metal portion of the console control head. Your treadmill will not start and operate without this. Removing the magnet also secures the treadmill from unauthorized use.
2. Fasten the plastic clip onto your clothing securely to assure good holding power. Note: The magnet has strong enough power to minimize accidental, unexpected stopping. The clip should be attached securely to make certain it does not come off. Be familiar with its function and limitations. The treadmill will stop, depending on speed, with a one to two step coast anytime the magnet is pulled off the console. Use the Stop / Pause switch in normal operation.

Task	How To	Daily	Weekly	Monthly	Semi-Annually	Annually
Wipe Down Unit	Damp cloth w/ water	•				
Clean Under Belt	Towel or vacuum			•		
Check Belt Tension/Tracking	Feel/Visual		•			
Clean Under Motor Cover	Vacuum carefully				•	
Check Hardware	Wrench			•		
Inspect for Deck Wear	Visual				•	
Inspect Drive Belt	Visual				•	

BELT/DECK

Your treadmill uses a very high-efficient low-friction hard waxed deck. Performance is maximized when the deck is kept as clean as possible. Use a soft, damp cloth, or paper towel, wipe the edge of the belt and the area between the belt edge and the frame. Also reach as far as practical directly under the belt edge. This should be done once a month to extend belt and deck life. A mild soap and water solution along with a nylon scrub brush will clean the top of the textured belt. Allow to dry before using.

The low maintenance (routine monthly cleaning), dual sided hard wax deck is designed to withstand up to 20,000 miles on each side. If the original side of the deck shows significant wear, it needs to be flipped. Contact your service technician for assistance. Do not apply any type of lubricant or wax to the surface.

BELT ADJUSTMENTS

Tread-belt Tension Adjustment - Belt tension is not critical for most users. It is very important though for joggers and runners in order to provide a smooth, steady running surface.

Adjustment must be made from the rear roller with the 8mm Allen wrench provided in the parts package. The adjustment bolts are located at the end of the step rails as shown in the diagram to the right.

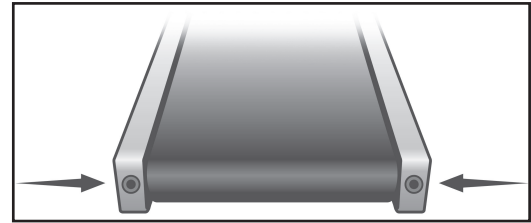

Tighten the rear roller only enough to prevent slippage at the front roller. Turn the tread-belt tension adjusting bolts 1/4 turn each and inspect for proper tension by walking on the belt and making sure it is not slipping or hesitating with each step. When an adjustment is made to the belt tension, you must be sure to turn the bolts on both sides evenly or the belt could start tracking to one side instead of running in the middle of the deck.

DO NOT OVER TIGHTEN – Over tightening will cause belt damage and premature bearing failure. If you tighten the belt a lot and it still slips, the problem could actually be the drive belt - located under the motor cover - that connects the motor to the front roller. If that belt is loose it feels similar to the walking belt being loose. Tightening the motor belt should be done by a trained service person.

TREADBELT TRACKING ADJUSTMENT

The treadmill is designed so that the tread-belt remains reasonably centered while in use. It is normal for some belts to drift near one side while in use, depending on a user's gait and if they favor one leg. But if during use the belt continues to move toward one side, adjustments are necessary.

SETTING TREAD-BELT TRACKING

An 8mm Allen wrench is provided for this adjustment. Make tracking adjustments on the left side bolt. Set belt speed at 3 mph. Be aware that a small adjustment can make a dramatic difference which may not be apparent right away. If the belt is too close to the left side, then turn the bolt only a 1/4 turn to the right (clockwise) and wait a few minutes for the belt to adjust itself. Continue to make 1/4 turns until the belt stabilizes in the center of the running deck.

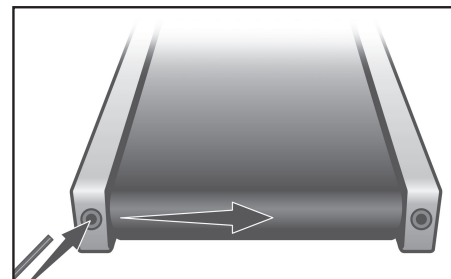

If the belt is too close to the right side, turn the bolt counter-clockwise. The belt may require periodic tracking adjustment depending on use and walking/running characteristics. Some users may affect tracking differently. Expect to make adjustments as required to center the tread-belt. Adjustments will become less of a maintenance concern as the belt is used. Proper belt tracking is an owner responsibility common with all treadmills.

ATTENTION: Damage to the running belt resulting from improper tracking / tension adjustments is not covered under the Spirit Fitness warranty.

CALIBRATION PROCEDURE

1. Remove the safety button
2. Press and hold down the **Start** and **Fast +** buttons and replace the safety button. Continue to hold the **Start** and **Fast** button until the window displays "Factory settings", then press the **Enter** button.
3. You will now be able to set the display to show Metric or English settings (Miles vs. Kilometers). To do this, press the **Up** or **Down** button to show which you want, then press **Enter**.
4. Make sure the wheel size diameter is 2.98 then press **Enter**.
5. Adjust the minimum speed (if needed) to 0.5 and then press **Enter**.
6. Adjust the maximum speed (if needed) to 12.0 and then press **Enter**.
7. Adjust the maximum elevation (if needed) to 15 and then press **Enter**.
8. Grade return – On (This allows the incline to return to zero when **Stop** is pressed. For sale in Europe, EU standards require this to be off)
9. Press **Start** to begin calibration. The process is automatic; the speed will start up without warning, so do not stand on the belt.

ADJUSTING THE SPEED SENSOR

If the calibration does not pass you may need to check the speed sensor alignment.

1. Remove the motor cover hood by loosening the 8 screws that hold it in place. Set it aside.
2. The speed sensor is located on the left side of the frame, right next to the front roller pulley (the pulley will have a belt around it that also goes to the motor). The speed sensor is a small rectangular shaped black box with a wire connected to it.
3. You will see a magnet on the outside edge of the pulley; make sure the speed sensor is aligned with the center of the magnet when it passes by. There are two screws that hold the sensor in place that need to be loosened to adjust the sensor. Retighten the screws when finished.

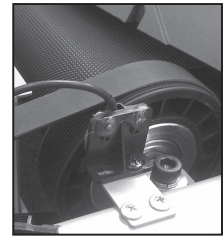

SERVICE CHECKLIST - DIAGNOSIS GUIDE

PROBLEM	SOLUTION/CAUSE
Display does not light	<ol style="list-style-type: none"> 1. Tether cord not in position. 2. Circuit breaker on front grill tripped. Push circuit breaker in until it locks. 3. Plug is disconnected. Make sure plug is firmly pushed into 115 VAC wall outlet. 4. Breaker panel circuit breaker may be tripped. 5. Treadmill defect. Contact your Spirit Fitness dealer.
Tread-belt does not stay centered Treadmill belt hesitates when walked/run on	The user may be walking while favoring or putting more weight on either the left or right foot. If this walking pattern is natural, track the belt slightly off-center to the side opposite from the belt movement. See General Maintenance section on Tread-belt Tension . Adjust as necessary.
Motor is not responsive after pressing start	<ol style="list-style-type: none"> 1. If the belt moves, but stops after a short time and the display shows "LS", run calibration. 2. If you press start and the belt never moves, then the display shows LS, contact service.
Circuit breaker trips, but not the treadmill circuit breaker	Need to replace the breaker with a "High In-rush current" type breaker (see page 3 for details)

<p>Treadmill will only achieve approximately 7 mph but shows higher speed on display</p>	<p>This indicates motor should be receiving power to operate. Low AC voltage to treadmill. Do not use an extension cord. If an extension cord is required it should be as short as possible and heavy duty 16 gauge minimum. Low voltage. Contact an electrician or your Spirit Fitness dealer. A minimum of 110 volt AC current is required.</p>
<p>Tread-belt stops quickly/suddenly when tether cord is pulled</p>	<p>High belt/deck friction. See General Maintenance section on cleaning the deck. If cleaning doesn't prevent this from reoccurring, check to see if there is significant wear of the deck. If so, the deck may need to be flipped if it is on its original side</p>
<p>Treadmill trips on board 15 amp circuit</p>	<p>High belt/deck friction. See General Maintenance. If cleaning doesn't prevent this from reoccurring, check the amp draw of the motor. If this is high and there are signs of significant wear of the deck, it may need to be flipped if it is on its original side</p>
<p>Computer shuts off when console is touched (on a cold day) while walking/running</p>	<p>Treadmill may not be grounded. Static electricity is "crashing" the computer. Refer to Grounding Instructions on page 5.</p>

GENERAL MAINTENANCE

1. Wipe down all areas in the sweat path with a damp cloth after each workout.
2. If a squeak, thump, clicking or rough feeling develops the main cause is most likely one of two reasons:
 - a. The hardware was not sufficiently tightened during assembly. All bolts that were installed during assembly need to be tightened as much as possible. It may be necessary to use a larger wrench than the one provided if you cannot tighten the bolts sufficiently. I cannot stress this point enough; 90% of calls to the service department for noise issues can be traced to loose hardware.
 - b. The crank arm nut needs to be retightened
 - c. If squeaks or other noises persist, check that the unit is properly leveled. There are 2 leveling pads on the bottom of the rear stabilizer, use a 14mm wrench (or adjustable wrench) to adjust the levelers.

ENGINEERING MODE MENU

The console has built in maintenance/diagnostic software. The software will allow you to change the console settings from English to Metric and turn off the beeping of the speaker when a button is pressed for example. To enter the Engineering Mode Menu, press and hold down the **Start**, **Stop** and **Enter** buttons. Keep holding the buttons down for about 5 seconds and the Message Center will display Engineering Mode Menu. Press the **Enter** button to access the menu below:

1. Button Test (Will allow you to test all the buttons to make sure they are functioning)
2. LCD Test (Tests all the display functions)
3. Functions (Press Enter to access settings and Up arrow to scroll)
 - a. Sleep Mode (Turn on to have the console power down automatically after 20 minutes of inactivity)
 - b. Pause Mode (Turn on allow 5 minutes of pause, turn off to have the console pause indefinitely)
 - c. ODO Reset (Resets the odometer)
 - d. Units (Sets the display to readout in English or Metric display measurements)
 - e. Beep (Turns off the speaker so no beeping sound is heard)
 - f. DA Test (Tests the brake resistance)
4. Security (Allows the buttonpad to be locked to prevent unauthorized use)

SETTING MILEAGE LOCK

1. Remove the safety button, press and hold numeric buttons **1, 2, 3** at the same time then return the safety button to enter setting function.
2. Message Window will display "LOCK SETTING = ON/OFF".
3. Press **Fast/Slow/Up/Down** buttons to set On or Off then press **Enter**.
4. If Off is set, it returns to idle mode. If On is set, it enters code setting procedure.
5. Now Message Window will display "PASSWORD = ****". Use numeric buttons in order to set a 4-digit security code. Press **Enter** when complete.
6. Enter the code again to confirm. Press **Enter** when complete.
7. Now Message Window will show "MILEAGE = XXX Km". Use **Fast/Slow/Up/Down** buttons to set the required mileage. Press **Enter** when complete. Now the Message Window window will show "LOCK SETTING OK" and return to Idle Mode.
8. To unlock, press and hold numeric buttons **1, 2, 3** at the same time to enter unlocking function.

RESETTING CUMULATED DISTANCE/TIME

1. Remove the safety button and press numeric button **0** and **Enter** then return the safety button to enter displaying the version of cumulated distance and time. Total time is shown on Time Window while total mileage and software version in the Message Window.
2. To clear the value, press numeric buttons **7 - 8 - 9 - 7**, then press **Enter** button to reset total mileage and time to zero.
3. Press **Stop** button to exit and return Idle Mode.

TREADMILL WARRANTY EFFECTIVE DECEMBER 23, 2015

Spirit Fitness warrants all its Treadmill parts for a period of time listed below from the date of retail sale, as determined by sale receipt, or in the absence of a sales receipt eighteen (18) months from the original factory shipping date. Spirit Fitness' responsibilities include providing new or remanufactured parts, at Spirit Fitness' option, and technical support to our independent dealers and servicing organizations. In the absence of a dealer or service organization, these warranties will be administered by Spirit Fitness directly to a consumer. The warranty period applies to the following components:

Warranty	Frame	Motor/Deck	Parts	Labor
Commercial	Lifetime	5 Years	5 Years	2 Year
Residential	Lifetime	Lifetime	10 Years	2 Year

NORMAL RESPONSIBILITIES OF THE CONSUMER

The consumer or non-dues paying facility is responsible for the items listed below:

1. The warranty registration card must be completed and returned to the address listed on the card within 10 days of the original purchase, or completed online to validate the manufacturer's limited warranty.
2. Proper use of the fitness equipment in accordance with the instructions provided in this manual
3. Proper installation in accordance with instructions provided with the fitness equipment and with all local electric codes.
4. Proper connection to a grounded power supply of sufficient voltage, replacement of blown fuses, repair of loose connections or defects in house or facility wiring.
5. Expenses for making the fitness equipment accessible for servicing, including any item that was not part of the fitness equipment at the time it was shipped from the factory.
6. Damages to the fitness equipment finish during shipping, installation or following installation.
7. Routine maintenance of this unit as specified in this manual.

EXCLUSIONS

This warranty does not cover the following:

1. CONSEQUENTIAL, COLLATERAL, OR INCIDENTAL DAMAGES SUCH AS PROPERTY DAMAGE AND INCIDENTAL EXPENSES RESULTING FROM ANY BREACH OF THIS WRITTEN OR ANY IMPLIED WARRANTY.
Note: Some states do not allow the exclusion or limitation of incidental or consequential damages, so this limitation or exclusion may not apply to you.
2. Service call reimbursement to the consumer. Service call reimbursement to the dealer that does not involve malfunction or defects in workmanship or material, for units that are beyond the warranty period, for units that are beyond the service call reimbursement period, for fitness equipment not requiring component replacement, or fitness equipment not in non-dues paying facility or household use.
3. Damages caused by services performed by persons other than authorized Spirit Fitness service companies; use of parts other than original Spirit Fitness parts; or external causes such as corrosion, discoloration of paint or plastic, alterations, modifications, abuse, misuse, accident, improper maintenance, inadequate power supply, or acts of God.
4. Products with original serial numbers that have been removed or altered.
5. Products that have been: sold, transferred, bartered, or given to a third party.
6. Products that do not have a warranty registration card on file at Spirit Fitness. Spirit Fitness reserves the right to request proof of purchase if no warranty record exists for the product.
7. THIS WARRANTY IS EXPRESSLY IN LIEU OF ALL OTHER WARRANTIES EXPRESSED OR IMPLIED, INCLUDING THE WARRANTIES OF MERCHANTABILITY AND/OR FITNESS FOR A PARTICULAR PURPOSE.
8. Product used in a dues paying facility (YMCA, Health Club, Etc.)
9. Product used in prisons and correctional facilities
10. Warranties outside of the United States may vary. Please contact your local dealer for details.

SERVICE

Keep your bill of sale. Twelve (12) months from the date on the bill of sale or eighteen (18) months from the date of factory shipping as determined by the serial number establishes the labor warranty period should service be required. If service is performed, it is in your best interest to obtain and keep all receipts. This written warranty gives you specific legal rights. You may also have other rights that vary from state to state.

Service under this warranty must be obtained by following these steps, in order:

1. Contact your selling authorized Spirit Fitness dealer. OR
2. Contact your local authorized Spirit Fitness service organization.
3. If there is a question as to where to obtain service, contact our service department at (870) 935-1107.
4. Spirit Fitness' obligation under this warranty is limited to repairing or replacing, at Spirit Fitness' option, the product through one of our authorized service centers. All repairs must be preauthorized by Spirit Fitness. If the product is shipped to a service center freight charges to and from the service center will be the customer's responsibility. For replacement parts shipped while the product is under warranty, the customer will be responsible for shipping and handling charges. For in-home service, the customer will be responsible for a trip charge. There will be an additional trip charge if the customer is located over 100 miles from the nearest service center.
5. The owner is responsible for adequate packaging upon return to Spirit Fitness. Spirit Fitness is not responsible for damages in shipping. Make all freight damage claims with the appropriate freight carrier. **DO NOT SHIP ANY UNIT TO OUR FACTORY WITHOUT A RETURN AUTHORIZATION NUMBER.** All units arriving without a return authorization number will be refused.
6. For any further information, or to contact our service department by mail, send your correspondence to:

SPIRIT FITNESS, INC.
P.O. Box 2037
Jonesboro, AR 72402-2037

Product features or specifications as described or illustrated are subject to change without notice. All warranties are made by Spirit Manufacturing, Inc. This warranty applies only in the 48 contiguous United States. NOTE: This does not apply to Alaska or Hawaii.



800.258.4555
spiritservice@spiritfitness.com
www.spiritfitness.com



Spirit Fitness
3000 Nestle Road
Jonesboro, AR 72401



CT850 Owners Manual
© 2018 All Rights Reserved
Revision: 08.22.2018